



WHD-04

Electromechanical Wicket Gate
for indoor application



Technical Specification

Application: This wicket gate is ideal for indoor applications requiring free access in one direction and banned access in the other. Its elegant design presents a secure and stylish solution that can blend into entrances of office, shopping and showroom facilities, airports and other passenger terminals, etc.

Function: The WHD-04 wicket gate is intended for bi-directional single or multiple passages. Passage can be controlled in either direction.

Design: The WHD-04 consists of a gate post, a swing panel with info sign, a remote switching and power unit, a remote control panel and a set of cables.

The indication module (Red / Green status lights) mounted on the gate post displays the gate status. The remote switching and power unit (the SPU) is responsible for the gate powering and providing the gate control.

Red / Green status lights: Come as standard with the gate post.

The illuminated Red light indicates the following:

- the wicket gate is ready for use and activation upon receiving an appropriate control signal from the control panel or ACS controller; passage is not available;
- passage is denied if an invalid access key has been presented.

The illuminated Green light indicates that the passage is authorized and available.



**Control
Mechanism
Components:**

The rotation unit with fixed swing panel is located on the upper part of the gate post. The gate post contains a reset unit, an electromagnetic locking device, a control logic board (CLB), optical rotation sensors, and optical sensors of the locking device:

- after each passage the swing panel automatically returns to the home position; the smoothness of reset is ensured by a hydraulic damper;
- optical rotation sensors are activated / inactivated in a certain sequence during the panel swing and track real passage events through the wicket gate thus ensuring accurate data input into T&A systems.

Control over Gate:

The WHD-04 wicket gate can be operated:

- from the remote control panel or a wireless remote control;
- from an access control system (ACS) via an ACS controller.

The WHD-04 is a normally open (N/O) unit, i.e. it is always unlocked unless unauthorized entry is attempted.

Upon power loss the WHD-04 operates in a "Fail-Safe" mode – free swing in both directions.

The standard gate is a bi-directional unit but it may be configured as a single direction gate – a mechanical rotation limiter included in the standard delivery set allows to set one-way turn of the swing panel (one-way electric control).

Interface:

The WHD-04 is operated by electrical control signals from the remote control panel / ACS controller received on the corresponding CLB contacts.

The CLB, the SPU and the remote control panel / ACS controller are connected by cables according to the wiring diagram.

The SPU is a stand-alone device in a metal case with pull-resistant fasteners for wall mounting. It can also be desk-mounted.

The SPU case contains a power transformer, an SPU board and a 12V battery of the standby power supply (SPS).

The CLB and SPU electronics are protected against short circuits, overloads and polarity inversion.

**Operating Modes*:**

Four operating modes can be set from the remote control panel**:

- single passage (the swing panel can be turned once in either direction);
- double passage (the swing panel can be turned twice irrespective of the direction);
- free passage (the swing panel can be turned many times in both directions);
- blocked passage (turn of the swing panel is blocked in both directions).

Note.

* The operating modes are indicated for the standard gate configuration without the rotation limiter.

** If the wicket gate is operated via an ACS controller, the operating modes are set by ACS control signals.

**Principle of Operation:**

In the single passage mode, upon receiving an appropriate signal from access control system or the remote control panel (the Green status light on the indication module is on), the swing panel can be pushed by hand in either direction.

When the swing panel has turned and the passage is completed, the reset unit returns the swing panel to the home position; the Red status light is on - the wicket gate is ready for the next control command.

In other operating modes the gate operates in a similar way.

The swing panel rotation speed (i.e. the speed of the passage) depends on the value of the force applied to the swing panel to push.

Timeout Facility:

The WHD-04 has a preset timeout period of 5 sec (the passage

waiting time) during which a passage through the gate is allowed. If the wicket gate is operated via an ACS controller, the passage waiting time is set by ACS control signals.

If in the single passage mode the swing panel is not turned within this timeout period (no response signals from the optical rotation sensors), the CLB resets the wicket gate to the "Blocked passage" mode; the Red status light is on.

Power Failure:

The wicket gate is powered by 12V DC from the power source placed inside the SPU which in turn is supplied from either 220V / 50Hz AC mains or an external 12 V DC power supply via a "12 V" SPU connector.

In case of power failure the wicket gate remains in operation, the SPU switches to:

- the SPS battery included in the standard delivery set when the gate is powered from 220V / 50Hz AC mains;
- the in-built battery of an external 12V DC uninterruptible power supply (not included in the standard delivery set).

Hours of service depend on the built-in battery capacity.

At the SPS battery discharge down to 10.5 V the gate switches to the emergency mode: the swing panel is in the reset state; any setting of the operating modes from either the remote control panel or ACS is blocked.

Once the AC mains is restored, the wicket gate returns to normal operation, with automatic recharging of the SPS battery. Normal operation is resumed by setting the "Blocked passage" operating mode.

Materials:

Gate post:	steel, powder coated
Swing panel frame:	32 mm tube of brushed stainless steel AISI 304
Filler panel:	double-sided info sign, reinforced plastic

Available Colours and Finishes:

WHD-04R	- sandpaper powder coating with pearl mica effect; light beige colour
WHD-04G	- sandpaper powder coating with pearl mica effect; dark grey colour
WHD-04E	- high quality powder coating plus lacquered finish; «starlit night» colour

Powder coating to colour of choice (according to RAL) is available. Time of manufacture and price quotation are specified individually.

Transportation:

The wicket gate in the original package should be transported only in closed freight containers or other closed type cargo transport units.

Storage:

Storage of the WHD-04 is allowed at ambient temperatures from -50°C to +50°C. For extended periods of storage at extreme temperatures within allowable range, it is recommended to store the SPS battery separately from SPU following the storage requirement to sealed standby batteries.

Installation:

It is recommended to install the gate on a steady and level concrete floor (grade 400 or higher) or another firm foundation at least 150 mm thick.

The installation should be performed only by qualified personnel, in strict accordance with the manufacturer's instructions (supplied with the wicket gate), general electrical safety requirements and installation drawings.

Warranty:

The manufacturer guarantees the WHD-04 wicket gate complies with applicable statutory safety and electromagnetic requirements provided that the instructions on storage, installation and operation are observed.

The warranty period is 12 (twelve) months commencing from the date of sale.

Technical Specifications:

SPU power supply:	- 220 V / 50 Hz
- AC mains	- 12 V DC
- external power supply	12 V DC
Operational voltage	12 W
Power consumption, max	25 persons / min
Throughput rate in the single passage mode	1040×785×160 mm
Overall dimensions (H × W × D)	27 kg
Net weight	0°C to +40°C
Operating temperature range	

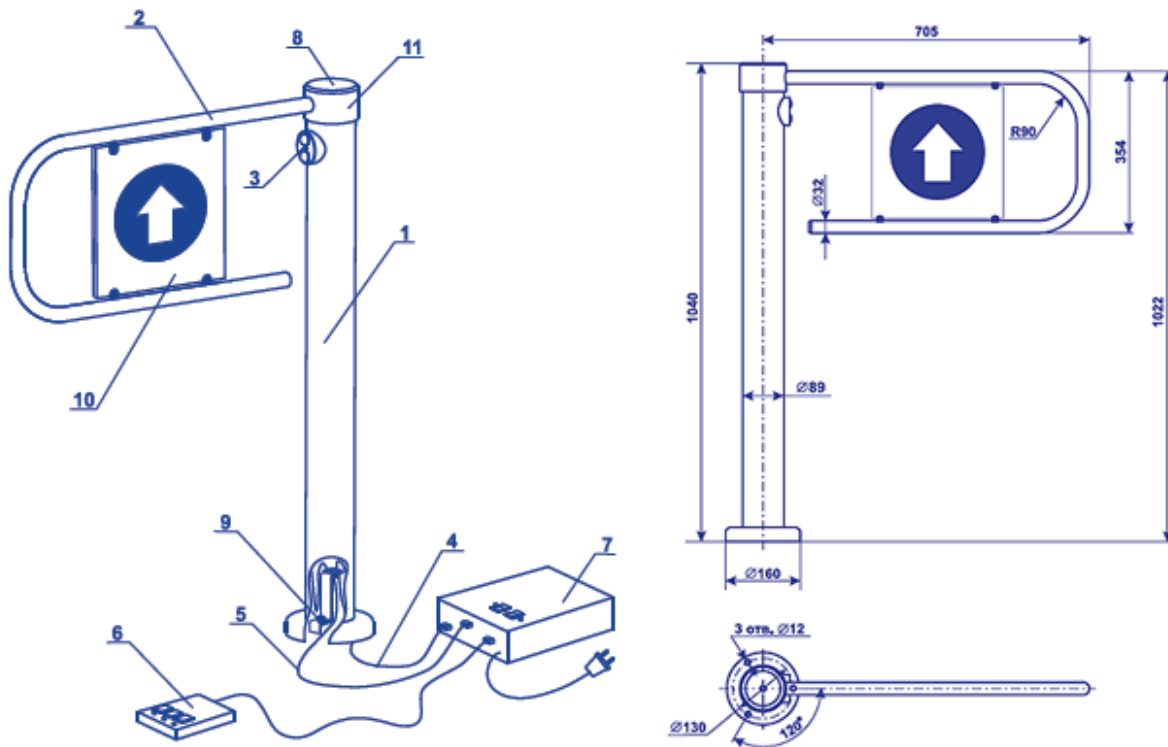

1 - gate post; 2 - swing panel; 3 - indication module; 4 - power cable; 5 - control cable; 6 - remote control panel with cable; 7 - switching and power unit (SPU); 8 - cover; 9 - M8 bolt; 10 - double - sided info sign with fasteners; 11 - rotation unit.

Installation Examples:



Standard Delivery Set:

- gate post with Red / Green status lights
- swing panel
- info sign
- SPU with built-in standby power supply
- remote control panel
- mechanical rotation limiter
- set of cables

Options:

- wireless remote control kit (operation range of up to 40 m)
-